

**Deck Specifications for:**

Name: \_\_\_\_\_

Address: \_\_\_\_\_

Legal Land Location: \_\_\_\_\_

Phone: \_\_\_\_\_

Contractor: \_\_\_\_\_ Phone: \_\_\_\_\_

**Specifications**

**Structure**

Attached:     Or Detached:     and size        x       

Provide the size in ft2 or m2           

if over 55m2 (592 ft2) or more than 600mm (2') off ground;

then provide piles (see page 4 of 4)

Footing pad (Detail "A") size:        x        x        thick

& must be reinforced

Provide distance between beams                           

*If deck is attached to a mobile dwelling;*

*then deck foundation to be same as mobile dwelling's foundation*

**Or** piles (Detail "B"; page 4 of 4)

& must be reinforced

Column size:       " x       " (i.e. 3 ply 2" x 6"/steel telepost)

Beam:                    ply of 2" x                   

Span between columns along beam:                           

Joists: 2" x 6", 8", 10" or 12" @                   " spacing

Attach joist to the ledger board with joist hangers; if attached

Distance between supports (i.e. ledger board to beam)                           

Provide joist cantilever length past beam                   

Permit # \_\_\_\_\_

Town/Village/RM of \_\_\_\_\_

Date: \_\_\_\_\_

<b>Wagner Inspection Services</b>
Contact Dale
@
225-2265 / 241-4741
wagnerdp@sasktel.net

**Safety**

Height from ground:   

Clearance from deck to overhead wires:                           

For height of deck guardrail & stair handrail

see pages 2 & 3.

Roof: No     Yes    , (If "yes" then piles are required for support

and plans to be Engineer stamped & site specific.)

Engineered trusses: (If yes     manufactured by -

  )

*If no, then* rafter & joist size       " x       "

Spaced                    apart with a            overhang

Thickness/type of sheathing:   

Type of shingles:

Decking material is \_\_\_\_\_ X \_\_\_\_\_ (i.e. radius/plywood/2"x 6")(if composite; then joists to be 16"o.c.)  
 Dimensional lumber/treated (i.e. 2" x 8") or other \_\_\_\_\_

**Wagner Inspection Services**  
 Contact Dale  
 @  
 225-2265 / 241-4741  
 wagnerdp@sasktel.net

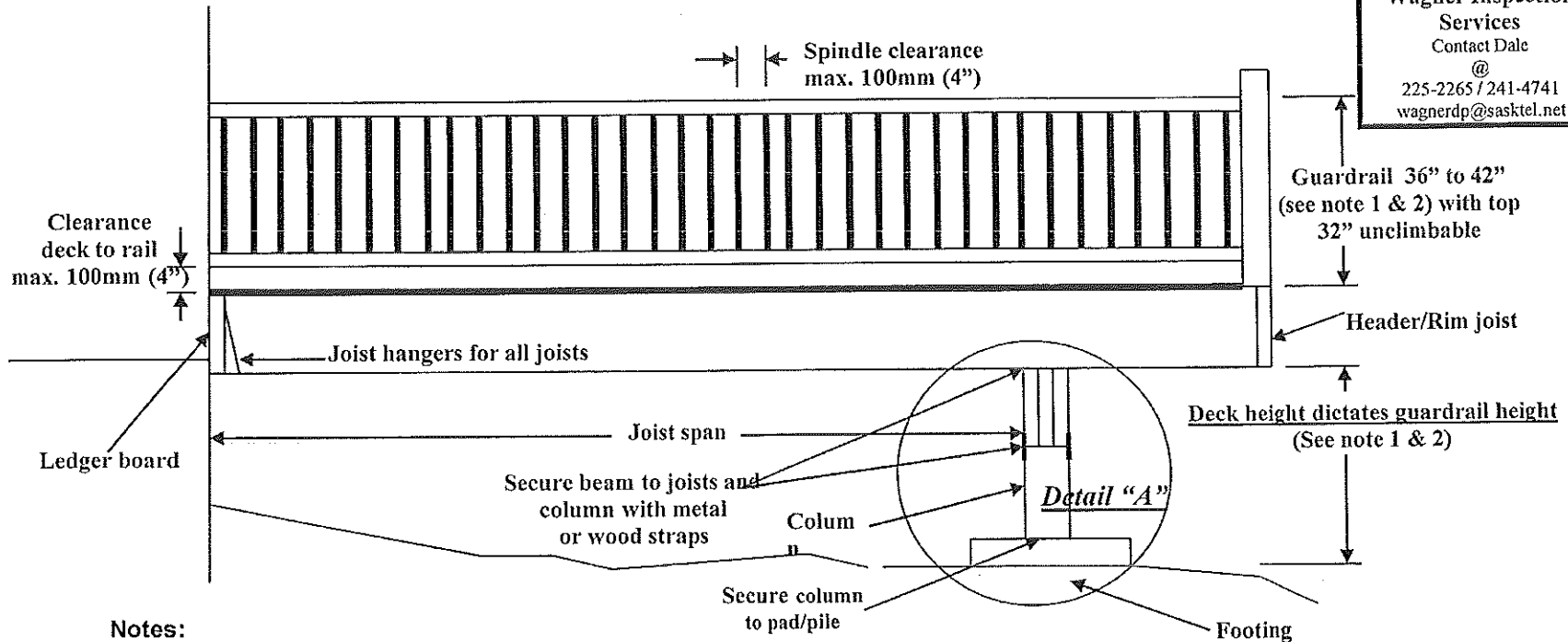

**Notes:**

1. Deck guardrails not to have a climbable foothold within 812mm (32") of top of rail.
2. Deck guardrail height - above deck surface @ 1070mm (42"), if deck surface is over 1.8m (6'). If deck surface is between 610mm (24") and 1.8m (6'), then the guardrail is 914mm (36").
3. Foundation is required if the deck is: (2005 NBC 9.12.2.2(7))

- |                      |   |
|----------------------|---|
| * May require        | * a. more than one storey.  |
| Eng. Stamp &         | b. more that 55m <sup>2</sup> (592 ft <sup>2</sup> ) in size.                 |
| site specific or see | c. more than 600mm (24") from the underside of joists to the finished ground. |
| page 4 of 4          | * d. supporting a roof.   |
|                      | * e. attached to another building structure (i.e. a house)                    |

4. Beam splice or joints should be over a column, (not more than 1/2 of the splices over one column)

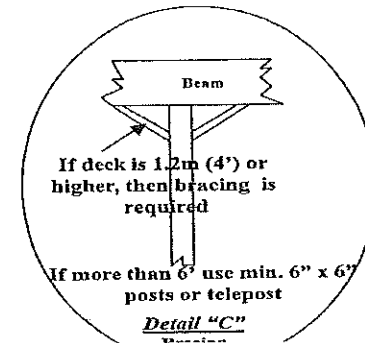

5. The cantilever of 2" x 10" joists is a maximum of 24".

Bracing

Typical Stairs and Plan View

Wagner Inspection Services  
 Contact Dale  
 @  
 225-2265 / 241-4741  
 wagnerdp@sasktel.net

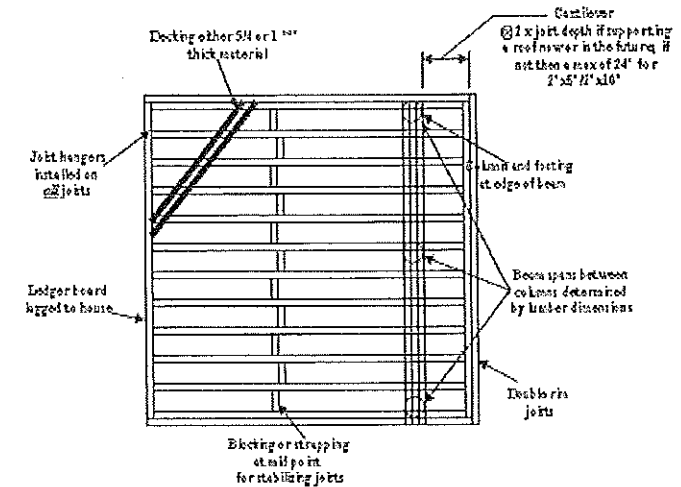
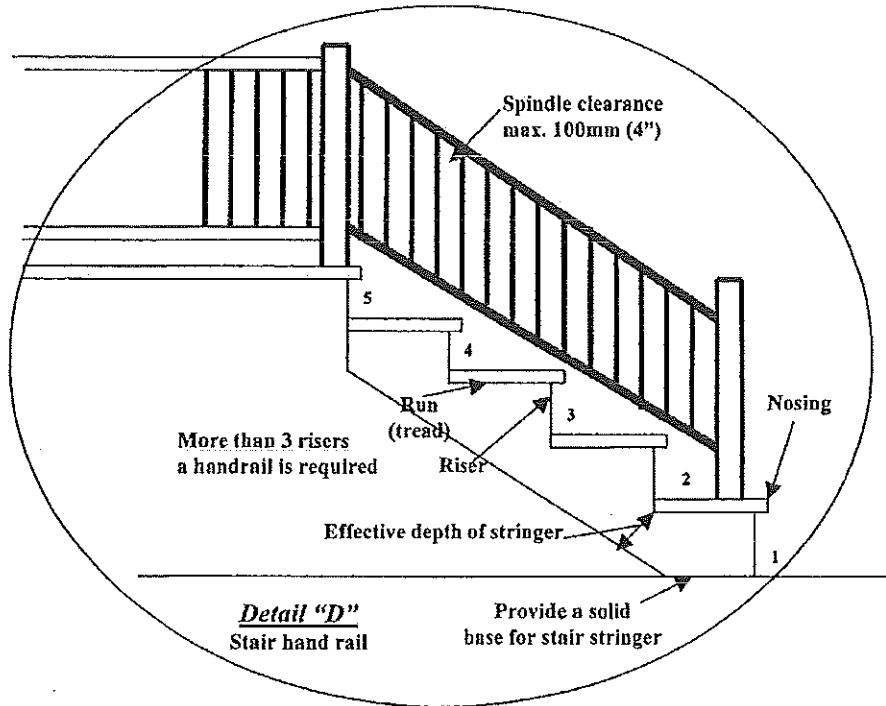

Notes:

1. Stair handrails - 800mm (31.5") min. and 965mm (38") max. above stair nosing (Detail "D").  
 Two handrails required for stairs or ramps over 1100mm (3' 7 5/16").
2. Stringer min. effective depth (Detail "D") - 90mm (3 1/2") and thickness 38mm (1 1/2") and stringer to be spaced not more than 900mm (3') o.c. for stairs not serving more than one dwelling unit and 600mm (2') o.c. in other stairs.
3. Tread/run (Detail "D") thickness 38mm (1 1/2") min. if stringers are more than 750mm (30") on center.
4. Tread width 900mm (36") o.c.
5. Min/max dimensions for Rise is 125mm (4 7/8") - 200mm (7 7/8"); Run is 210mm (8 1/4") - 355mm (14").
6. Guards are required if: (2005 NBC 9.8.7.1(1))
  - a. there is a difference in elevation of more than 600mm (24") between the walking surface and the deck surface or 3 risers.

- b. the adjacent surface within 1.2m (4') of the walking surface has a slope of more than 1 in 12 ( meaning a ratio of 1' out and 2' down).

### Recommended Pile Foundation (Detail B)

From page 2 of 3 it indicates a Engineer's stamp & site specific maybe require or do the following recommended pile foundation

Note:  
Pile spacing dependent on beam size and required support

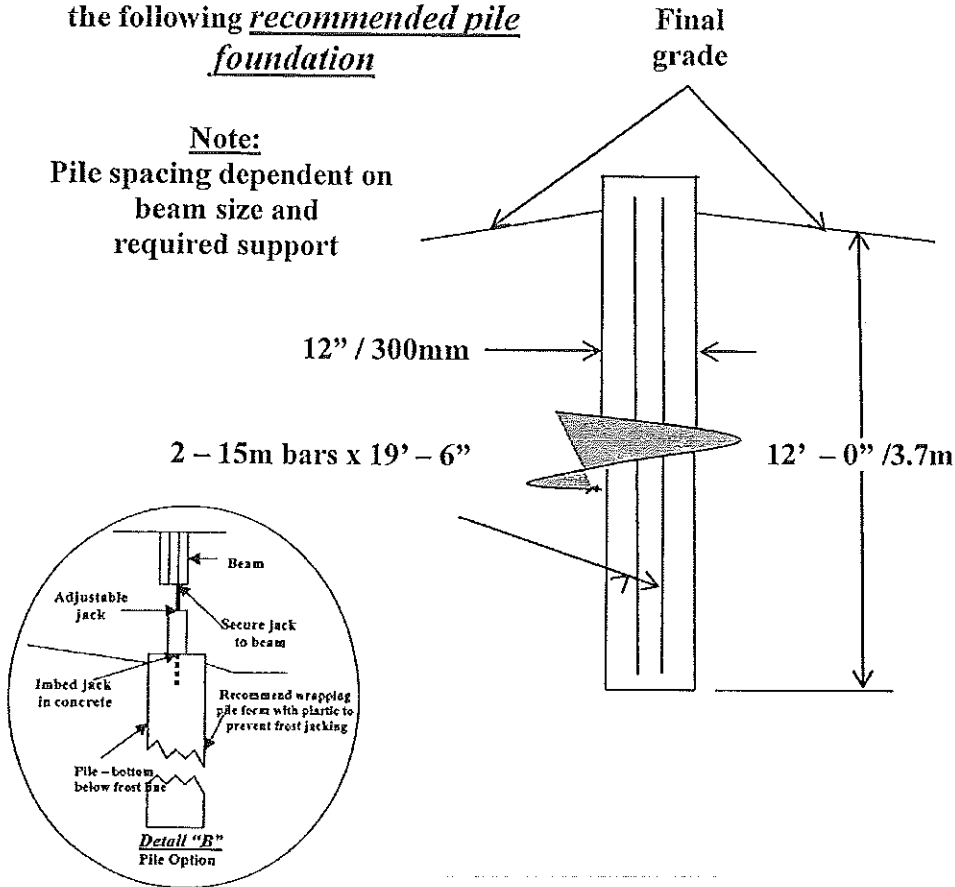

Wagner Inspection Services  
Contact Dale @ 225-2265 / 241-4741  
wagnerdp@sasktel.net

### Site Plan Required

- Provide lot dimensions, deck location with set backs from property line, existing buildings.
- Sketch of deck showing dimensions & location/direction of joists, beams & stairs

